

# Roll-In Docks, Cleat Assembly

ASSEMBLY INSTRUCTIONS

P/N 510-05369-00

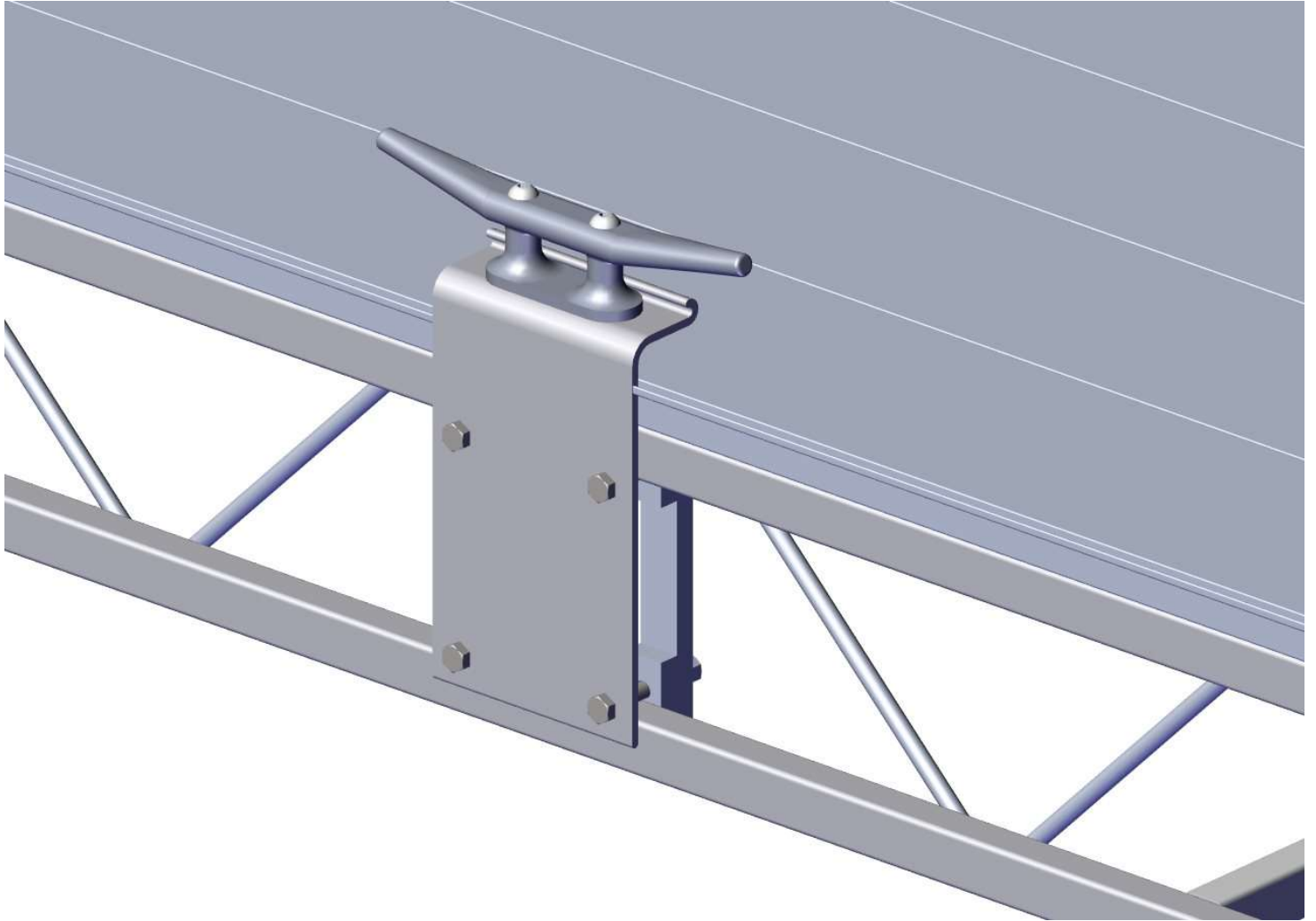

## Required Tools

- 7/32" Allen Wrench
- 9/16" Wrench or Socket
- Torque Wrench

INSTRUCTION P/N: 610-05369-00  
ISSUED: 06/23/20

SHEET 1 OF 4

© Manufactured by:  
Floe International Inc.  
48473 State Hwy. 65  
McGregor, MN 55760  
[www.floeintl.com](http://www.floeintl.com)

# ROLL IN DOCKS, CLEAT ASSEMBLY

EXPLODED VIEW AND BOM  
P/N 510-05369-00

ITEM	QTY	PART NUMBER	DESCRIPTION
1	2	001-37026-00	NUT, 3/8-16 JAM NYLOCK - ZINC
2	4	001-70114-00	HHCS, 3/8-16 x 2 3/4" ss
3	4	001-71067-00	LOCK WASHER, 18-8 ss
4	2	001-73821-00	BHCS, 3/8-16 X 2-1/2" SS 18-8
5	4	001-76349-00	NUT, 3/8-16 ALUM.
6	2	002-02203-00	PLATE, DOCK ACCESSORY
7	4	002-00204-00	SPACER, DOCK ACCESSORY
8	1	002-02558-00	BRACKET, ROLL-IN DOCK CLEAT
9	1	510-34300-00	DOCK CLEAT, 10" CAST ALUMINUM

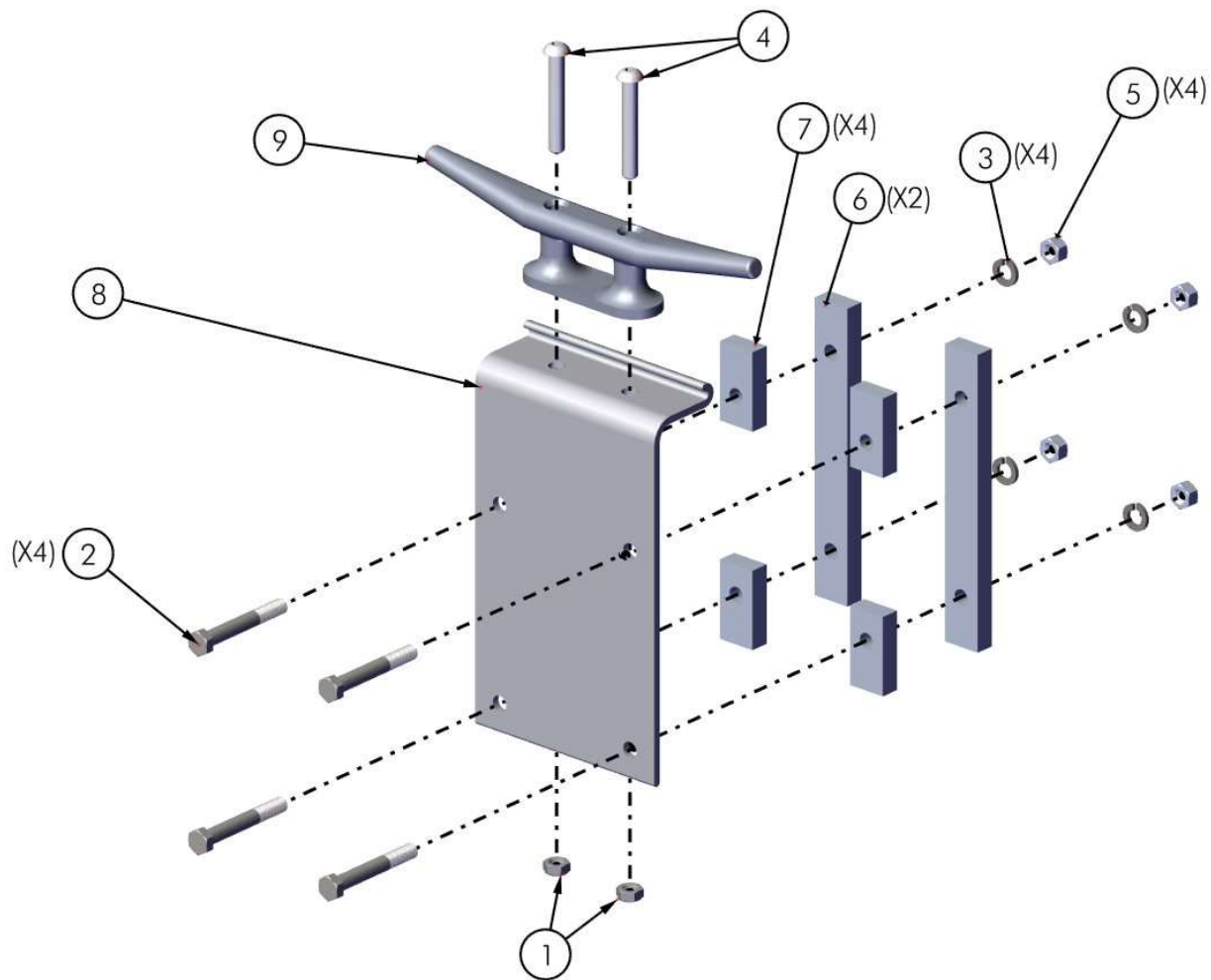

## STEP 1

DETERMINE DESIRED LOCATION FOR THE DOCK CLEAT. INSERT THE 3/8" X 2-3/4" BOLTS THROUGH THE CLEAT BRACKET ASSEMBLY AND THROUGH THE (4) DOCK SPACERS, PLATES, LOCK WASHERS, AND ALUMINUM NUTS ON THE OPPOSITE SIDE OF THE DOCK SIDE (FIGURE 1).

NOTE: THE LOWER BOLTS SHOULD BE ABOVE OR RESTING ON THE BOTTOM TUBE OF THE DOCK SIDE. ENSURE CAP SCREWS ARE NOT CONTACTING THE DOCK DECK.

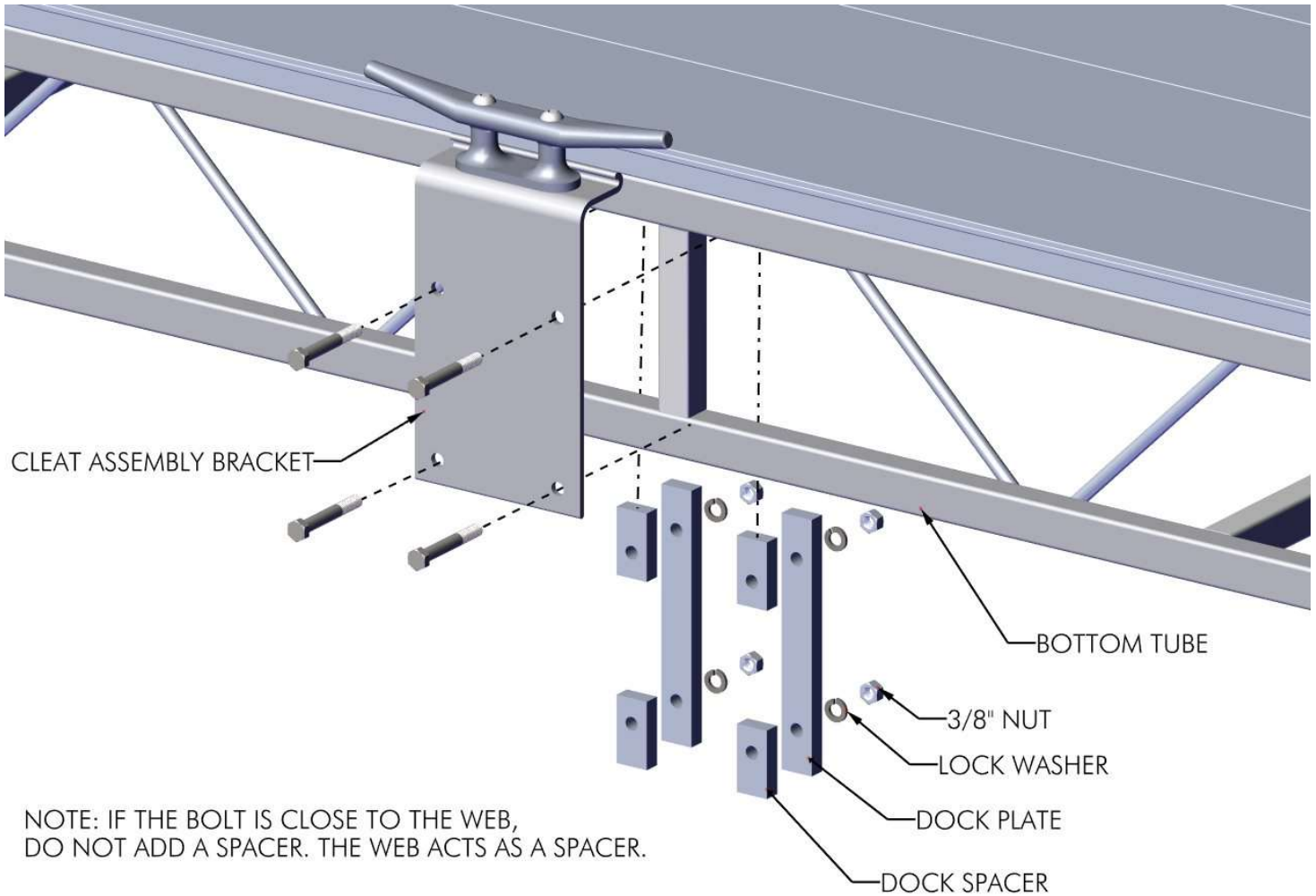

FIG. 1

## STEP 2

ONCE THE BOLTS ARE THROUGH AND THE CLEAT IS IN THE DESIRED LOCATION, FASTEN THE NUTS ONTO THE PLATES AND SPACERS (FIGURE 2). TORQUE NUTS AND BOLTS TO 35 FT-LBS.

NOTE: IF THE BOLT IS CLOSE TO THE WEB, DO NOT ADD A SPACER. THE WEB ACTS AS A SPACER (FIGURE 2).

**CAUTION DO NOT OVERTIGHTEN!**

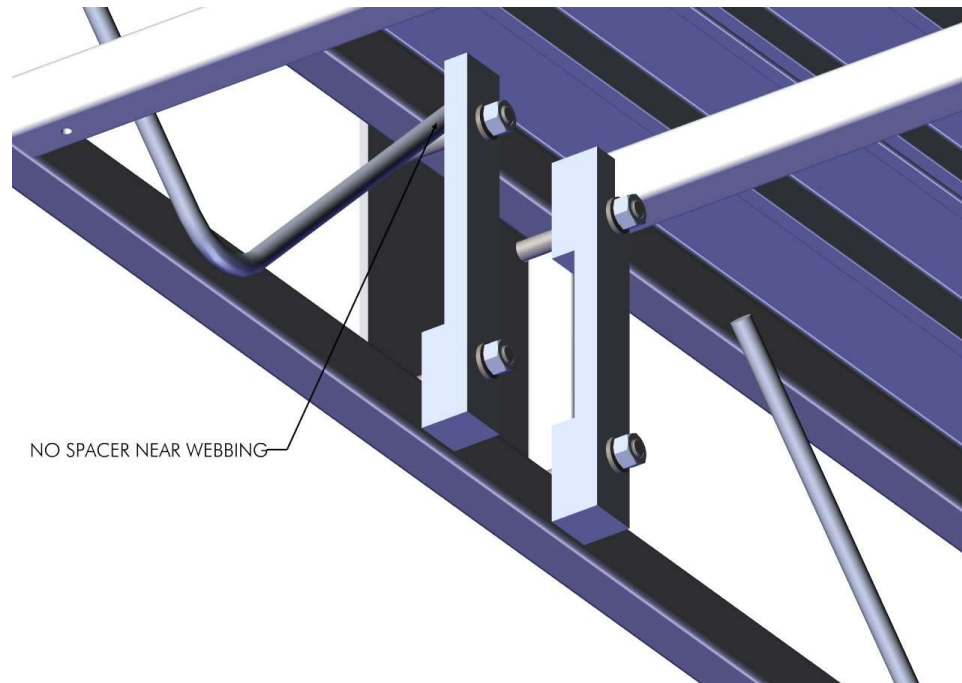

FIG. 2

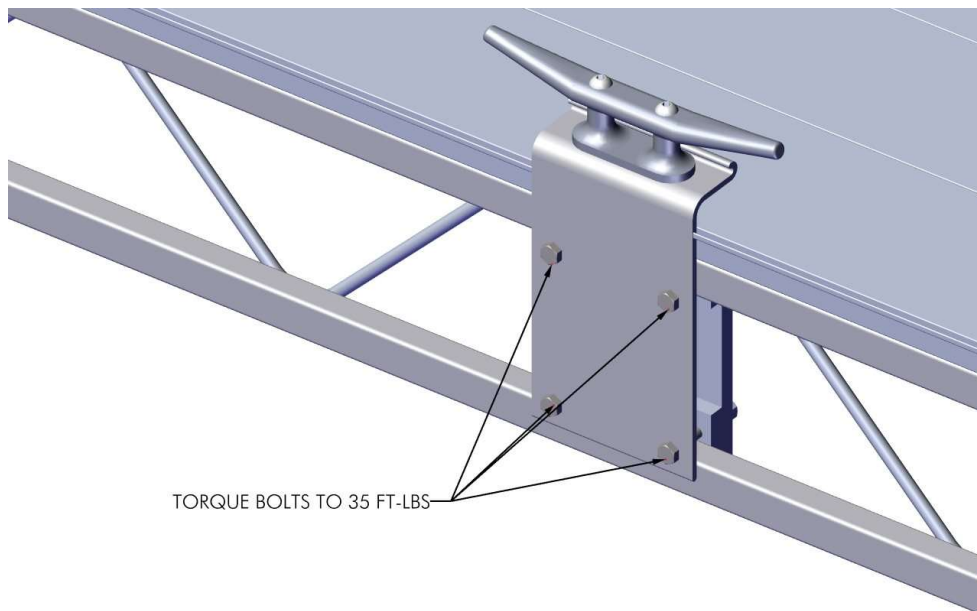

FIG. 3