

MANUAL WINCH
ASSEMBLY INSTRUCTIONS
P/N 511-36100-01 (V3600-V4600)



Manufactured by:
FLOE INTERNATIONAL, INC.
48473 State Hwy. 65
McGregor, MN 55760
www.floeintl.com



Tools Required

- (1) 3/4" socket for 1/2" nuts and bolts
- (1) 3/4" wrench for 1/2" nuts and bolts
- (2) 9/16" socket or wrench for 3/8" nuts and bolts
- (1) Torque wrench

Full Bill of Materials on Pages 3 & 4

STEP 1 - - - - -

Slide winch assembly on the lift post indicated in your lift owners manual.

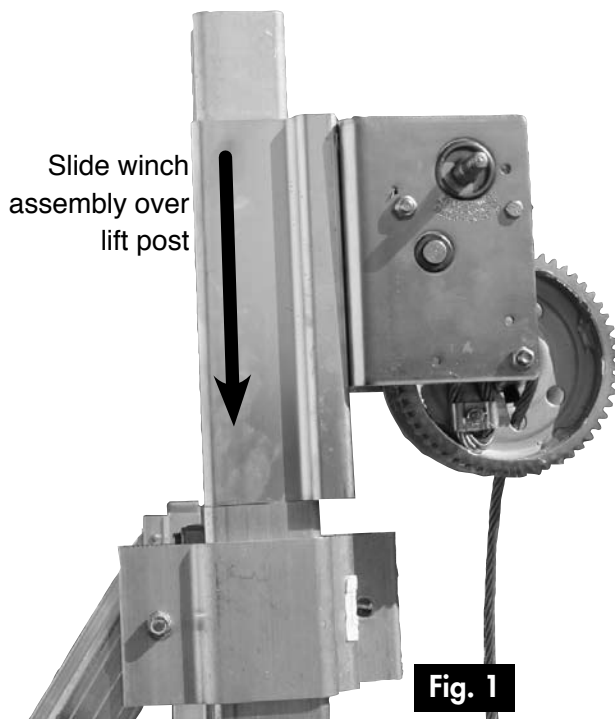

Fig. 1

STEP 2 - - - - -

Thread 1/2" low profile stainless steel jam nut onto eyebolt. Slide the flat washer onto the eyebolt. Slide the stainless nut into the slot at the top of the cradle beam clamp. Next, thread the eyebolt through the cradle beam clamp into the stainless nut until it bottoms out, as shown in Fig. 2. Orient the eyebolt at a 45 degree angle, so that the eyebolt points toward the corner formed by the cradle clamp and the corner post (Fig. 3). Keeping the eyebolt in place, torque 1/2" stainless steel jam nut down to 50 ft/lbs.

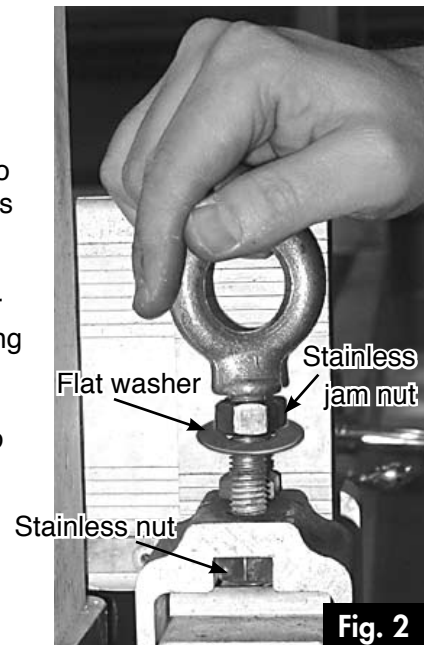
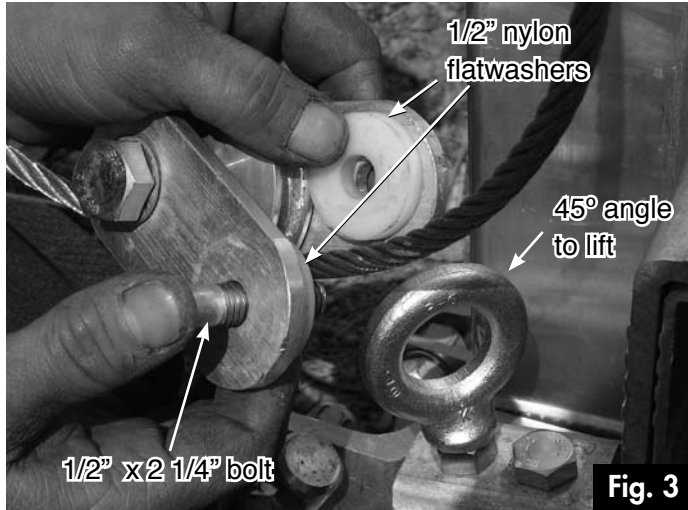

Fig. 2

STEP 3

Attach the 3" Winch Pulley Block to the lift by threading the cable and lining up the 1/2" nylon flatwashers with the 1/2" bolt holes on each pulley plate as shown (Fig. 3). When attaching to the eyebolt, ensure that the 1/2" x 2 1/4" bolt is running through the eyebolt and both nylon flatwashers. Then fasten and torque nylock nut to 20 ft/lbs. After assembly, make sure the pulley rotates freely.



STEP 4

Attach cable end to upper clamp. (Fig. 4) Torque the 1/2" x 2" stainless bolt with nylock nut to 50 ft/lbs.

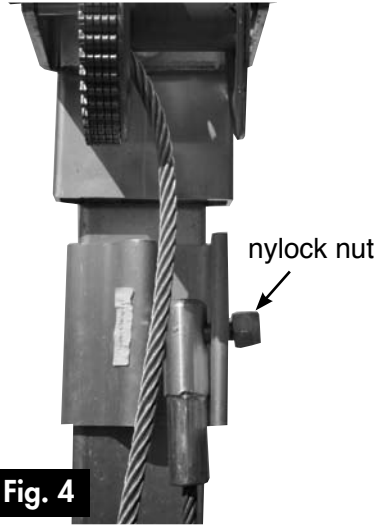

STEP 5

Fasten the winch wheel to the winch assembly by screwing it on the threaded stud exiting the winch assembly. Place the spacer onto the 5/16 x 1 1/4" bolt. Next place the washer onto the bolt over the spacer. Then screw the bolt with spacer and washer on it into the inner threads of the winch stud.

DO NOT INSTALL SPRING IF IT IS INCLUDED.



WARNING
DO NOT install spring that may be included in your hardware kit.
This part is for other applications. Installing this spring will cause damage and prevent your lift from working properly.

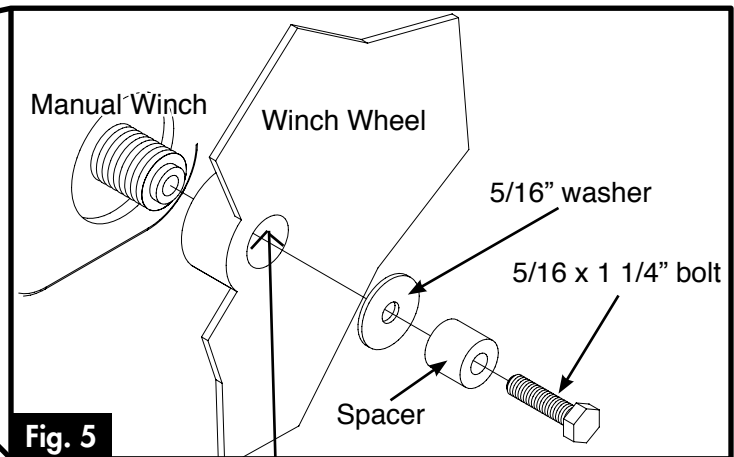

Apply a small amount of grease to the internal threads of the winch wheel to prevent rust. Be careful not to get any grease on the brake assembly.

BILL OF MATERIALS

P/N 511-36100-01 WINCH, V4600 MAN W/O WHEEL 2016

P/N 001-04108-00			
NUMBER	PART NUMBER	QTY.	DESCRIPTION
8A	001-42314-00	1	BOLT, LIFT EYE – MACH ½-13
8B	001-70211-00	1	HHCS, ½-13 x 2" 18-8 ss
8C	001-70212-00	1	HHCS, ½-13 x 2 ¼" 18-8 ss
8D	001-70714-00	1	NUT, ½ ss 18-8
8E	001-70814-00	1	NUT, JAM ½-13 ss 18-8
8F	001-71021-00	1	FLAT WASHER, ½" 18-8 SS
8G	001-71022-00	1	FLAT WASHER, ½" USS ss 18-8
8H	001-76072-00	2	NUT, NYLOCK ½-13 ALUM.
8I	007-05355-00	2	FLAT WASHER, ½" x .25" NYLON

8G: 001-71022-00 (FLAT WASHER, ½" USS ss 18-8) IS NOT USED WITH THIS KIT

P/N 111-00094-01			
ASS'Y, WINCH – V4600 2016			
NUMBER	PART NUMBER	QTY.	DESCRIPTION
1	001-70105-00	3	HHCS, 3/8-16 x 1" 18-8 ss
2	001-71018-00	6	FLAT WASHER, 3/8" USS ss 18-8
3	001-74421-00	1	CB, ¼-20 x 1 ¼" ss 18-8
4	001-76071-00	3	NUT, NYLOCK 3/8-16 ALUM.
5	002-04197-00	1	MOUNT, WINCH – 10" 2016
6	007-00800-00	1	WINCH, MANUAL – B3503
7	007-09600-00	1	CABLE, VERT. LIFT WINCH 143"

P/N 111-10103-00			
ASS'Y, 3" HD WINCH PULLEY			
NUMBER	PART NUMBER	QTY.	DESCRIPTION
9A	001-70312-00	1	HHCS, 5/8-11 x 2 ¼" ss 18-8
9B	001-71125-00	2	LOCK WASHER, INTERNAL STAR 5/8" ss
9C	001-76351-00	1	NUT, 5/8-11 ALUM
9D	007-06105-00	2	PLATE, SHEAVE ¼" THICK
9E	007-07713-00	1	SPACER, .625 x .872 x .937" LG
9F	007-07714-00	2	WASHER, NYLON 1.125 x .889 x .060
9G	111-00103-00	1	ASS'Y, 3" HD SHEAVE W/ BUSHING

P/N 511-04211-00			
KIT, HARDWARE – MAN. WINCH VERT			
NUMBER	PART NUMBER	QTY.	DESCRIPTION
8	001-04108-00	1	FASTENERS, WINCH (MANUAL)
9	111-10103-00	1	ASS'Y, 3" HD WINCH PULLEY

EXPLODED VIEWS

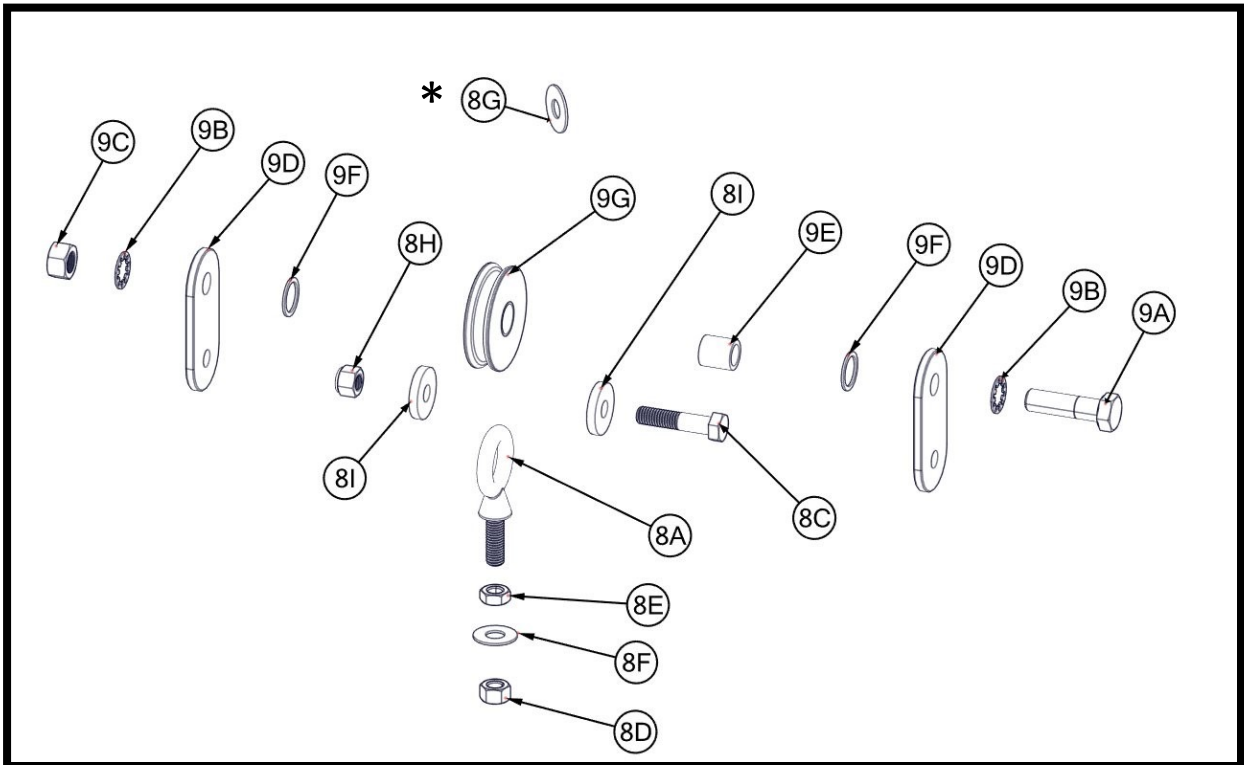
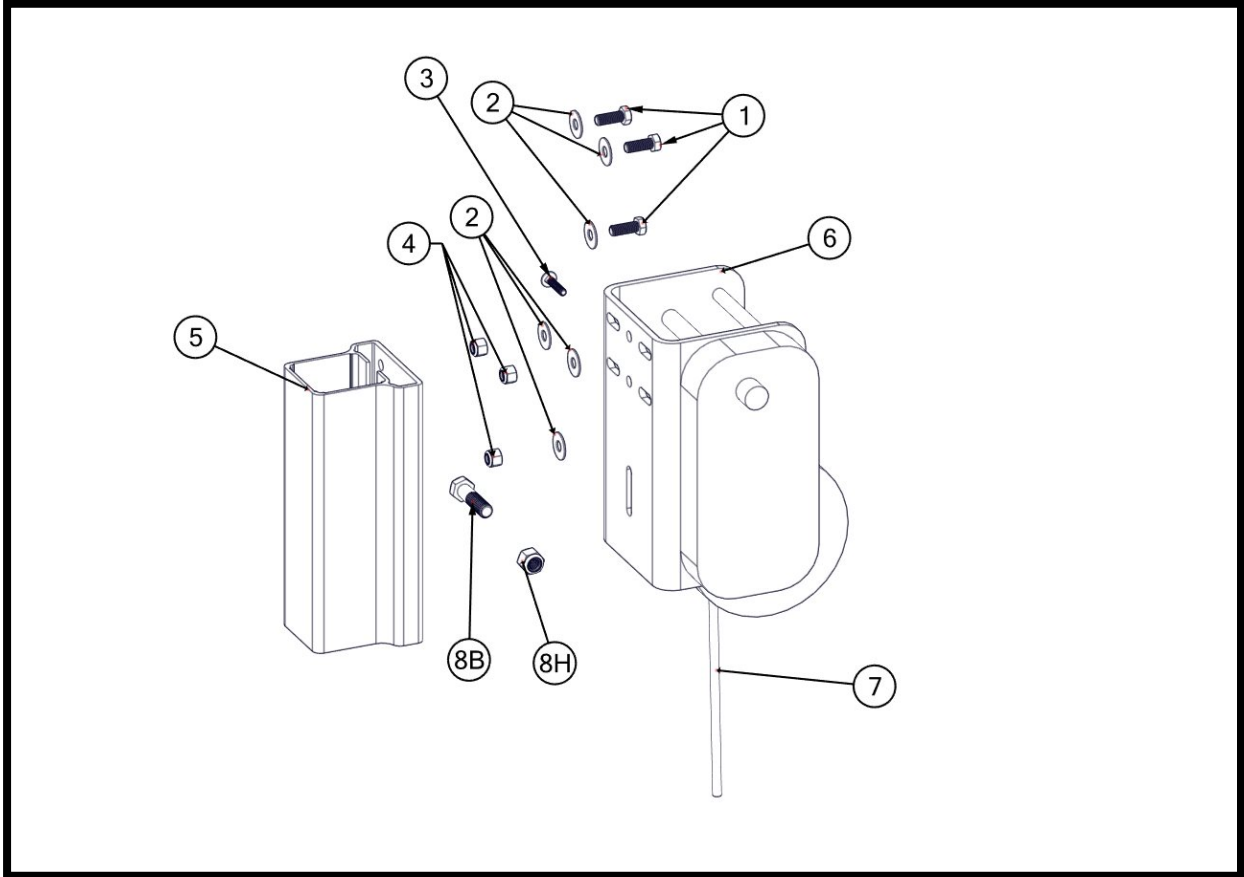

***8G: 001-71022-00 (FLAT WASHER, 1/2" USS ss 18-8) IS NOT USED WITH THIS KIT**