

SHOREWAY HINGE KIT ASSEMBLY INSTRUCTIONS

HARDWARE KIT P/N 510-05600-00/510-05601-00/510-05602-00

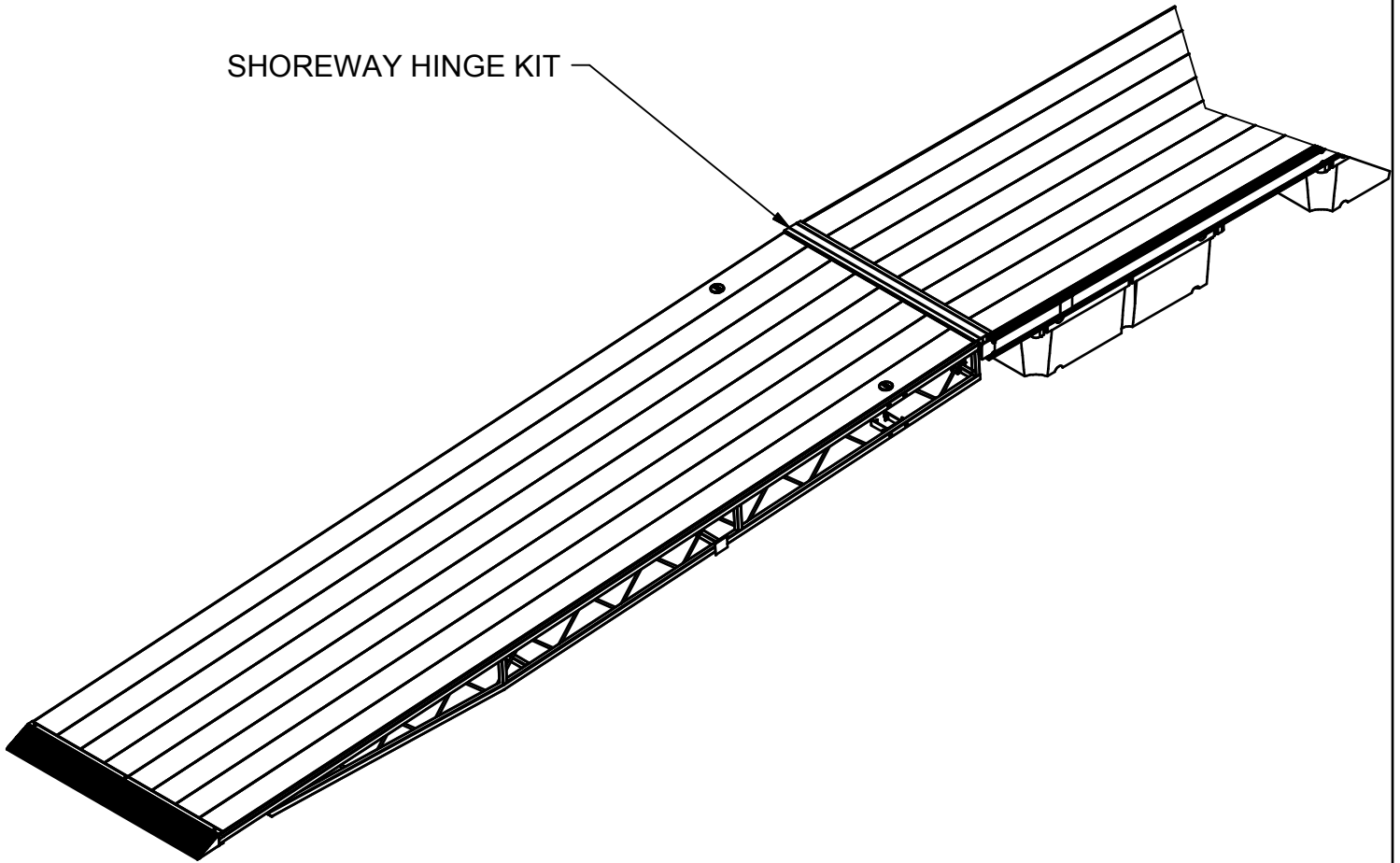

SHOREWAY HINGE KIT



TOOLS REQUIRED

- 9/16" SOCKET
- 9/16" WRENCH
- TORQUE WRENCH
- TAPE MEASURE

PARTS LIST/EXPLODED VIEW

ITEM	QTY	PART NUMBER	DESCRIPTION
1	2	001-70103-00	HHCS 3/8-16 X .75" SS
2	10	001-70105-00	HHCS 3/8-16 X 1" SS
3	10	001-70109-00	HHCS 3/8-16 X 1 1/2" SS
4	8	001-70115-00	HHCS 3/8-16 X 3" SS
5	30	001-71017-00	FLAT WASHER, 18-8 SS
6	28	001-76071-00	NUT, NYLOCK 3/8-16 ALUM.
7	2	001-76347-00	NUT, 3/8" ALUMINUM
8	4	002-02203-00	PLATE, DOCK ACCESSORY
9	8	002-02204-00	SPACER, DOCK ACCESSORY
10	10	002-02512-00	FLOATING DOCK HINGE, 3"
11	2	002-02525-00	PLATE, HINGE-FLOATING DOCK
12	2	110-00028-00	ASS'Y, HINGE ROD
13	2	110-05600-00	WELD'T, HINGE PLATE
14	1	REFER TO TABLE	TRIM, RAMP - 4'
15	1	REFER TO TABLE	PLATE, RAMP TRIM-4'

HARDWARE KIT FOR ALL SIZES OF SHOREWAY HINGE KITS. THERE MAY BE EXTRA HARDWARE DEPENDING ON SIZE PURCHASED.

TABLE		
RAMP WIDTH	TRIM PLATE P/N	TRIM P/N
4'	010-04907-00	002-02547-00
5'	010-04908-00	002-02548-00
6'	010-04909-00	002-02549-00

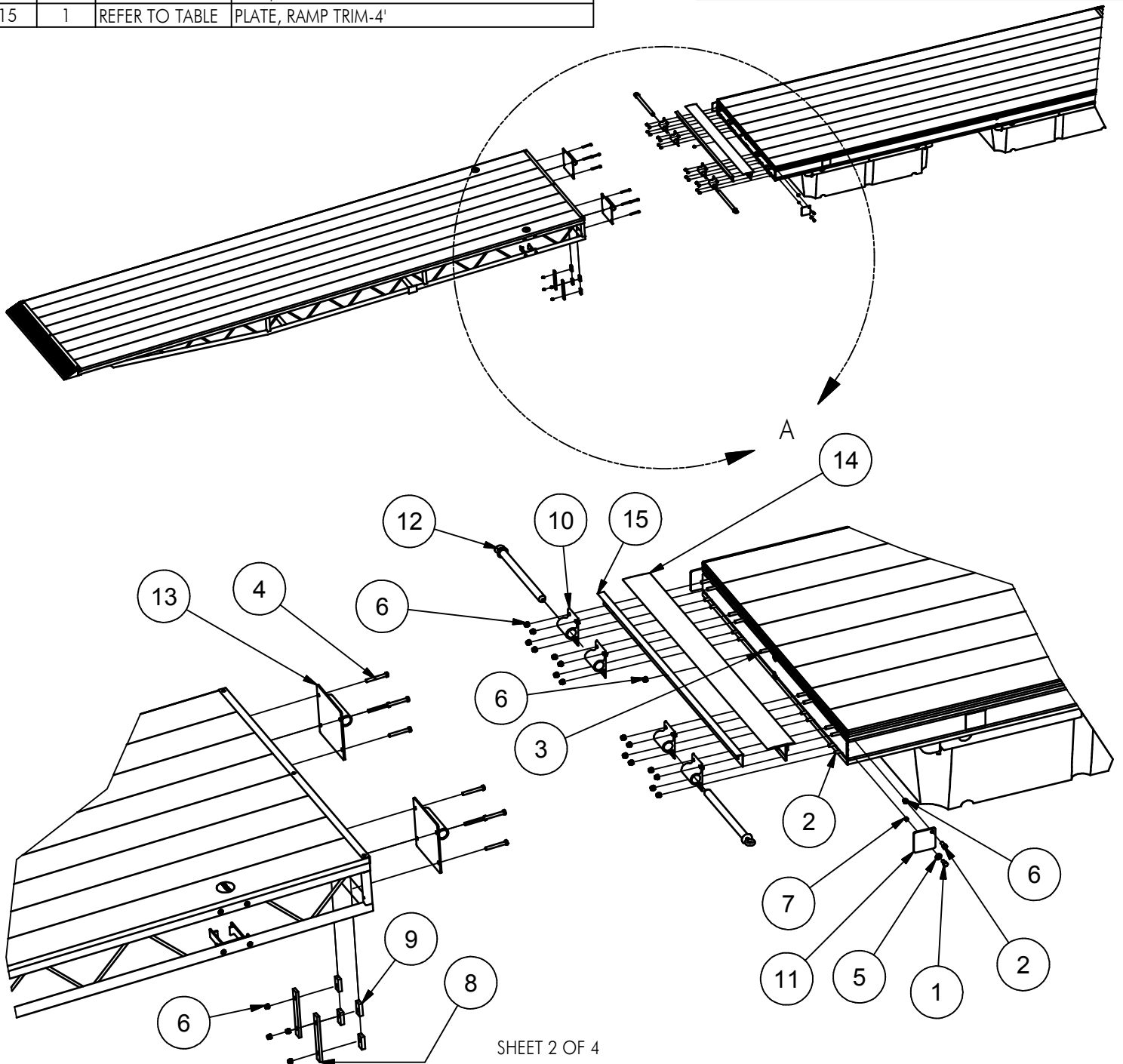

STEP 1

- SLIDE REQUIRED AMOUNT OF 3/8 X 1 1/2" BOLTS WITH FLATWASHERS INTO UPPER NUT TRACK. SLIDE (8) 3/8 X 1" BOLTS WITH FLATWASHERS INTO LOWER NUT TRACK. ALIGN 3/8 X 1 1/2" BOLTS WITH HOLES IN TRIM AND TRIM PLATE. SEE FIG. 1

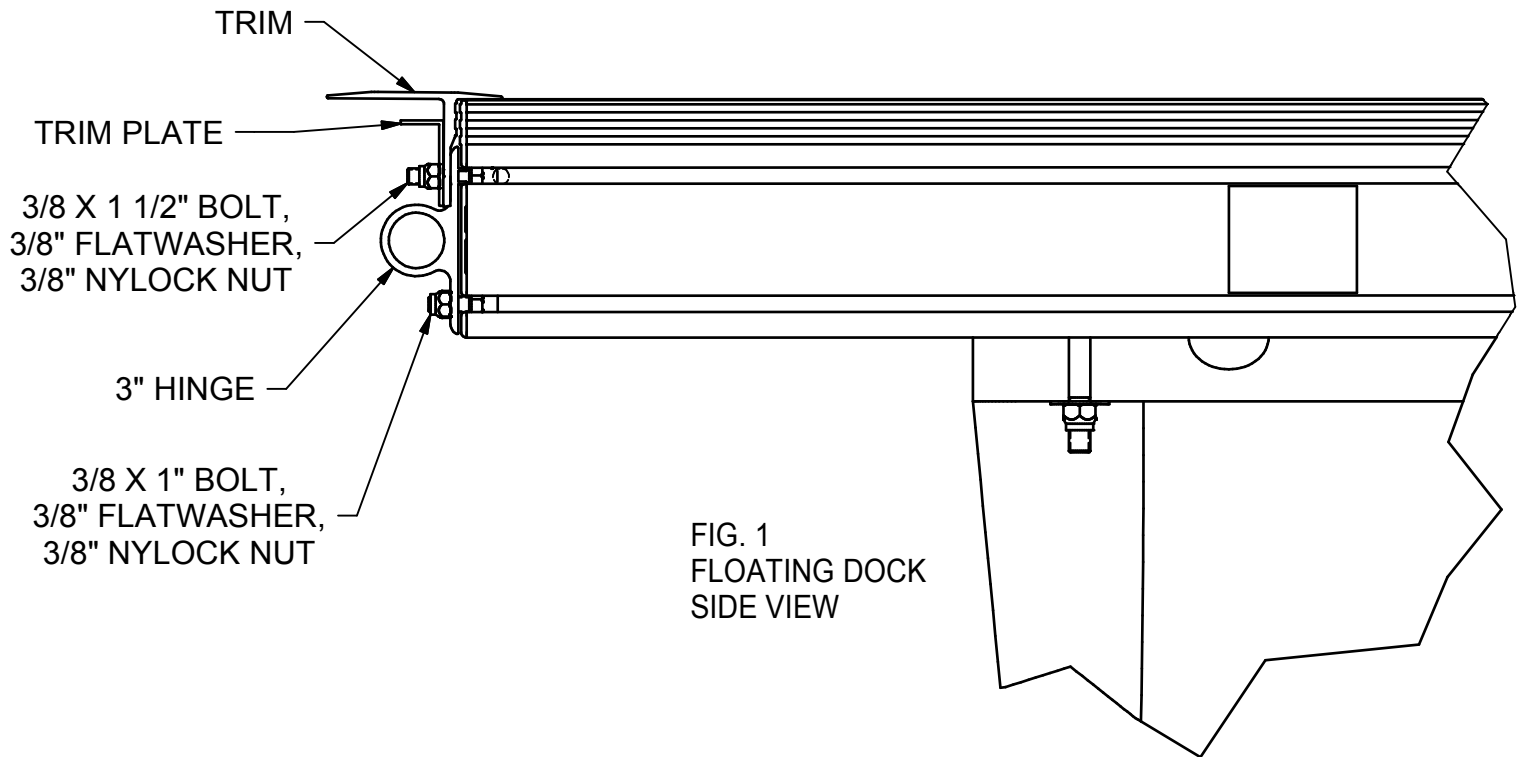

STEP 2

- LOCATE 3" HINGES AND TORQUE BOLTS TO 40 FT/LBS. SEE FIG. 2

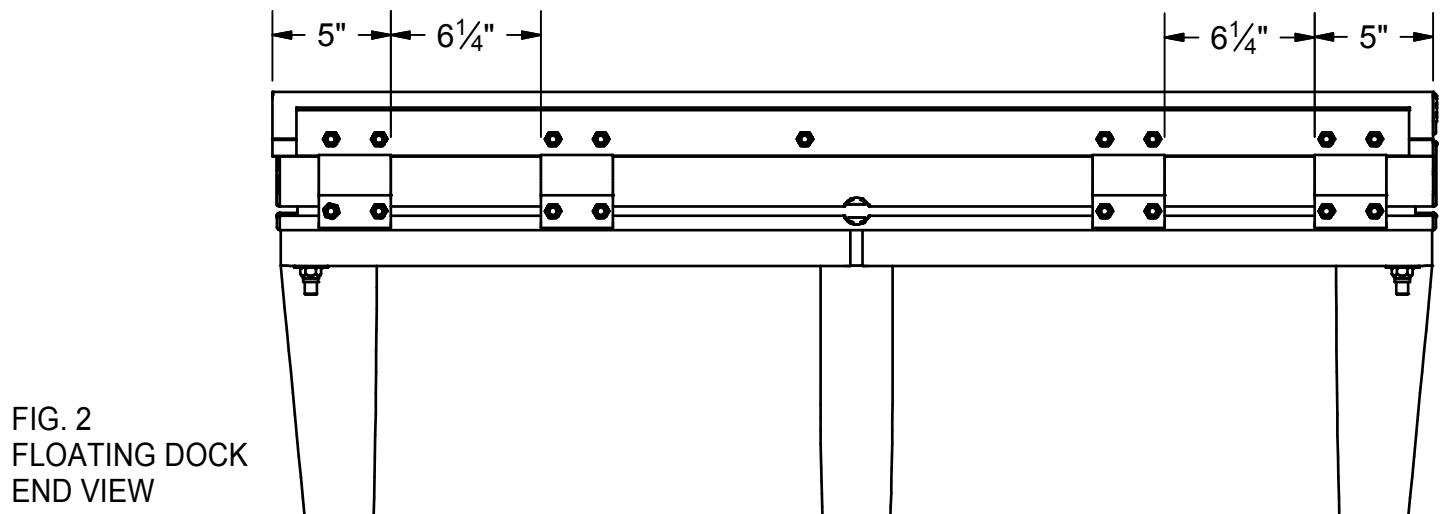

STEP 3

- INSERT 3/8 X 3" BOLT FROM THE OUTSIDE OF THE DOCK THROUGH HINGE PLATE.
- ON THE UNDERSIDE OF THE DOCK, ASSEMBLE DOCK SPACERS, DOCK PLATES, AND 3/8" NYLOCK NUTS. SEE FIG. 3 (IF SHOREWAY HAS WEBBING ON THE END, YOU MAY NOT NEED SPACER IF BOLT IS TOO CLOSE TO WEBBING)

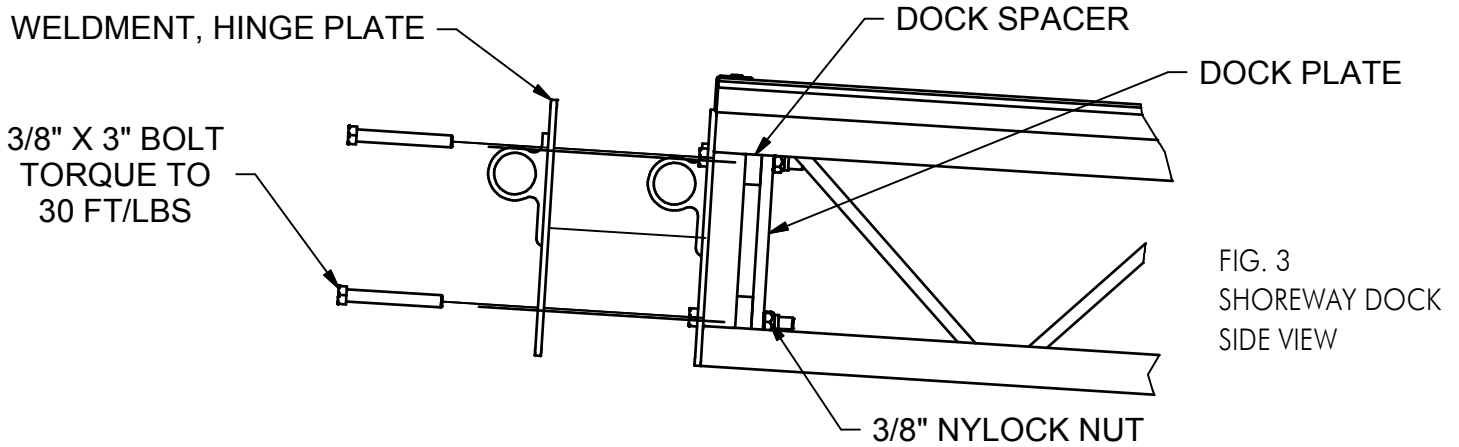

STEP 4

- LOCATE HINGES AND TORQUE BOLTS TO 40 FT/LBS. SEE FIG. 4

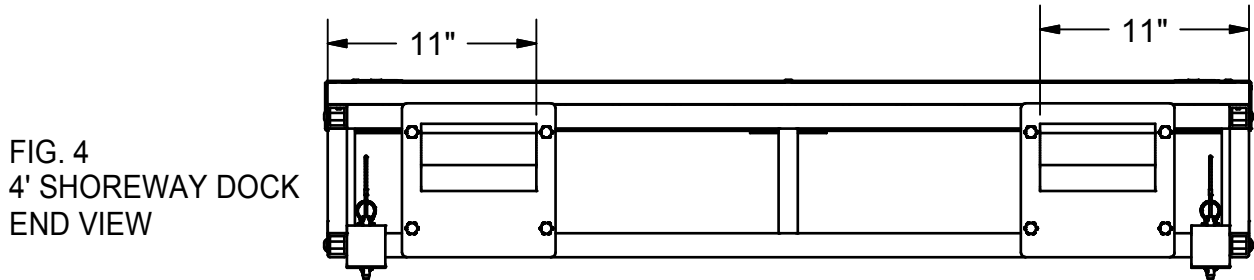

STEP 5

- POSITION SHOREWAY HINGES BETWEEN 3" HINGES AND INSERT HINGE PINS.
- INSERT 3/8" NYLOCK NUT AND WASHER INTO UPPER NUT TRACK.
- INSERT 3/8" NUT AND WASHER INTO LOWER NUT TRACK.
- INSERT 3/8 X 1" BOLT THRU HOLE IN HINGE PLATE AND INTO NYLOCK NUT IN UPPER TRACK.
- INSERT 3/8 X 3/4" BOLT WITH WASHER INTO NUT IN LOWER TRACK.
- POSITION HINGE PLATE OVER HINGE PIN AND TIGHTEN BOLTS.

SEE FIG. 5

